

# ZP218

## Parcel Shipping Scale

Ideal for busy, demanding parcel and shipping applications

*Technical Specification*



**Model ZP218**

## DESCRIPTION

The ZP218 durable 18" x 18" Bench Scale provides the best accurate and reliable weight measurement for static or in-line shipping applications.

Supplied with a built-in flush fitting, six digit 1" (25 mm) high backlit LCD display that is mounted centrally in the front face of the base.

An optional second remote display can be plugged in to provide the customer a facing weight reading.

A range of emulation protocols are available within the scale to allow you to quickly select the correct compatible communication protocol to interface with a wide range of third party post, mail and shipping software programs or

host devices. This will be communicated through either a serial RS-232, USB (HID) or USB (VCP) port found on the rear of the base.

## SPECIFICATIONS

### COMMUNICATION

#### Connectivity

1 x RS-232 (9 way female D Type connector ), 1 x USB HID (Mini USB) or 1x USB VCP (USB-Type B) 2<sup>nd</sup> Remote display connection (RJ 45) All are positioned on the rear of the base

#### Supported Protocols

4 Supported Protocols: NCI (default), SMA, Auto Weight Send 1, and Auto Weight Send 2 (9600 or 19200 baud rate). Includes as standard USB HID Keyboard Wedge output. USB VCP (Virtual COM Port) for use with downloadable USB VCP driver

## DISPLAY

<b>Display Type</b>	Flush fitting six digit, 1" (25 mm) high backlit LCD display. Optional 2nd remote six digit, 1" high backlit LCD display housed in an ABS enclosure with a 6 foot cable, connected via RJ 45 connector on the rear of the scale base
<b>Remote Display Housing Sizes</b>	8" x 3" x 1.5" (20cm x 7.6cm x 3.8cm)
<b>Operational Keys</b>	POWER/ZERO: Includes Auto Zero Tracking or Manual push button to re-establish zero reference UNITS: Allows you to select between lbs and kgs TARE: Perform a tare function for gross and net weigh
<b>Units of Measure</b>	lb, kg
<b>Configurable Selections</b>	Capacity, resolution, filters, baud rates, protocols, back light setting, and stand-by mode
<b>Time and Date</b>	No

### Base Sizes

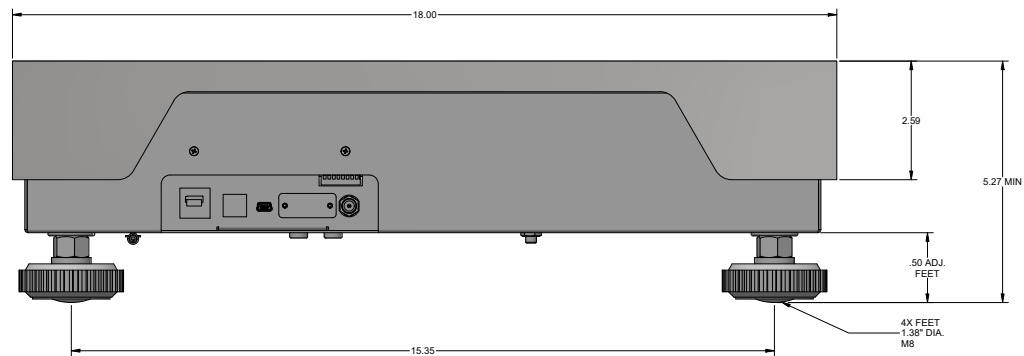

<b>Top Pan Construction</b>	Stainless steel weight platter Optional: Ball top weight platter (25 ball)
<b>Base Construction</b>	Painted all-metal frames and heavy duty overload protection using an aluminum analog load cell
<b>Base Capacity</b>	<b>Capacity (lb)</b> 150 lb x 0.05 lb (75 x 0.02kg) factory default With field calibration, configurable to: 100 x 0.02 lb (50 x 0.01kg)
<b>Power Adapter</b>	Input: 100-240VAC, 50/60Hz, 0.4A max Output: 12.0VDC, 1.0A max, 0.25mm barrel plus, center pin positive Type: Wall mount adapter with NA style two prong blade type
<b>Operating Environment</b>	Temperature: 42° F to 104° F (5° C to 40° C) Relative Humidity: 10 to 95% (non-condensing)
<b>Calibration</b>	2 point calibration process (zero and span capacity) Linear calibration Field calibration can be carried out by using less than full capacity weights Gravity compensation to allow the local gravity to be entered for where the scale is to be used
<b>Filtering</b>	Standard, Fast, or Slow

## OPTIONS

### Remote Customer Display

Allows for placement of weight display in a convenient location

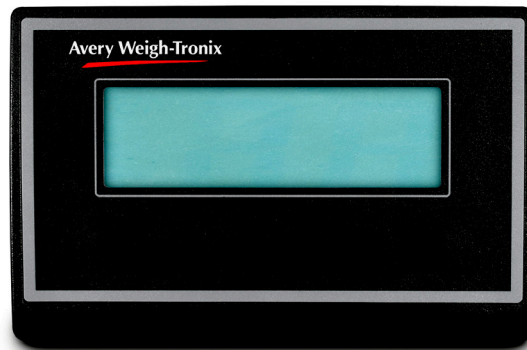

### Ball Top Weight Platter

Stainless steel, using 24 roller balls to simplify handling and transport of all parcels. One piece lift-off design for easy field retrofit



## APPROVALS

### Certifications

NTEP approved for use in Class III operations, CC 22-053  
Canada Weights and Measures approval: pending



---

# Avery Weigh-Tronix



[www.averyweigh-tronix.com](http://www.averyweigh-tronix.com)

*Avery Weigh-Tronix is an ITW company*

---

Avery Weigh-Tronix is a trademark of the Illinois Tool Works group of companies whose ultimate parent company is Illinois Tool Works Inc ("Illinois Tool Works"). Copyright © 2016 Illinois Tool Works. All rights reserved. This publication is issued to provide outline information only and may not be regarded as a representation relating to the products or services concerned. This publication was correct at the time of going to print, however Avery Weigh-Tronix reserves the right to alter without notice the specification, design, price or conditions of supply of any product or service at any time.