

# A&D Apollo

GF-AWP & GX-AWP

IP65 Protected  
Precision Balances



**A&D**  
A&D Weighing

# Industrial Washdown Protection on a Laboratory Precision Balance



## IP65 Dust and Water Ingress Protection

A&D is the only manufacturer to offer IP65 washdown protection on precision balances (0.001 g)

- IP 6X means completely protected against dust ingress
- IP X5 means protected against low pressure water jets from all directions

## Why is IP65 Important?

Corrosion of the internal boards is a common cause of equipment failure. Most balances are not rated to prevent moisture from getting inside the unit. With an IP65 balance you don't have to worry about accidental spills, high humidity environments or cleaning procedures causing damage to boards or critical electronics.

Additionally, 100% dust ingress protection means that they are perfect for use in dusty or powdery environments. The extra protection for the load cell compared to standard lab balances prevents any foreign material from entering the weighing unit, which is often the cause of failure in any environment dealing with fibers, dust, powders or loose granules.

## Warranty

A&D offers a 5 year warranty on all IP65 balances. This means that if you have a WP balance and the unit fails due to moisture or dust ingress, A&D will repair or replace the unit under warranty. Other manufacturers will void a warranty once damage due to water or dust has been identified because the units are not designed for those environments.

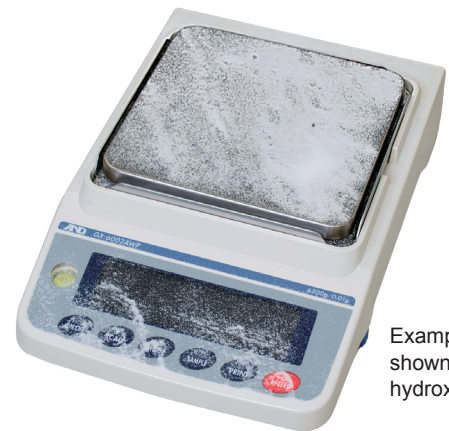

Example shown Sodium hydroxide

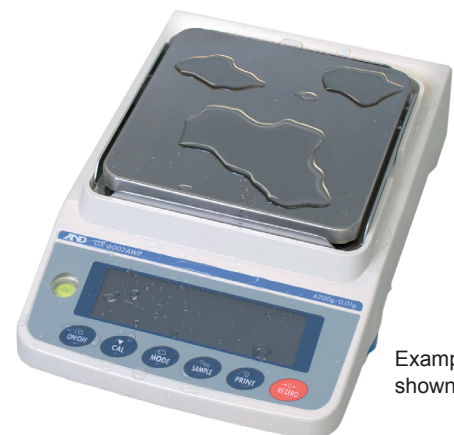

Example shown water

## Standard Features Include

**Internal Calibration:** Easy one touch button performs & documents internal calibration.

**Automatic Self-Calibration (ASC):** Auto calibrates based on temperature or time interval.

**Universal Flexi Coms (UFC):** Edit serial data output making label printing possible.

**Password-Protect:** Offers password-protection up to 11 users and 1 administrator.

**GLP/GMP/GCP Compliance:** Outputs manufacturer, model, serial number, ID, date, time, signature for full calibration report.

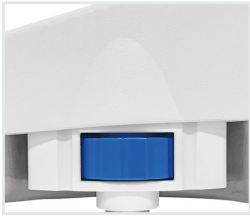

### Leveling Made Easy

- Plug in, turn on, screen blinks for 5 seconds to prompt user to level.
- Bright-bubble: Large, easy-to-see, front mounted spirit level with LED illumination.
- Fly-thumb wheel: Effortless & accessible. Allows ergonomic adjustment with anti-slip feet.



### Simple User Interface

- Six straightforward keys: ON/OFF, CAL, MODE, SAMPLE, PRINT, REZERO.
- Reverse Backlit LCD is a large display with clear B&W contrast providing excellent visibility.



### Cleanable Robust Construction

- Stainless Steel Pan & Dust-plate can be easily removed for cleaning .
- Easy to assemble anti-static breeze break on 0.001 readability models.
- Die-cast Aluminum housing provides extra stability and durability.



### Flexible Interface and Security

- Standard RS-232C & USB: Toggle between the Quick USB mode or Virtual COM mode (bi-directional). A USB cable comes standard.
- Security Slot: Anti-theft lock (such as Kensington) to prevent loss.

## Dimensions (mm/inch)

Models with readability of 0.01g and 0.1g

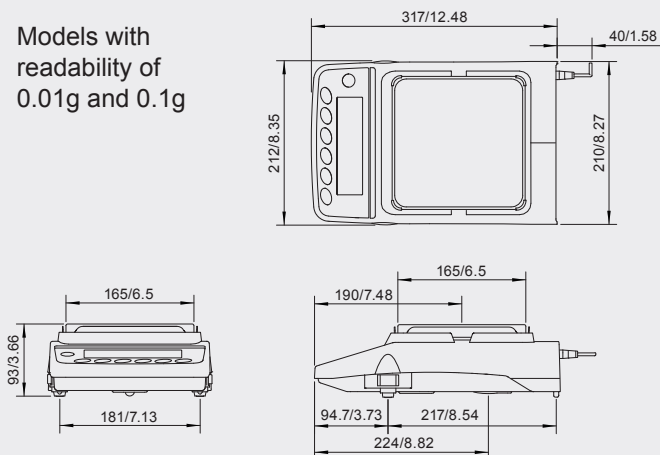

Models with readability of 0.01g and 0.1g

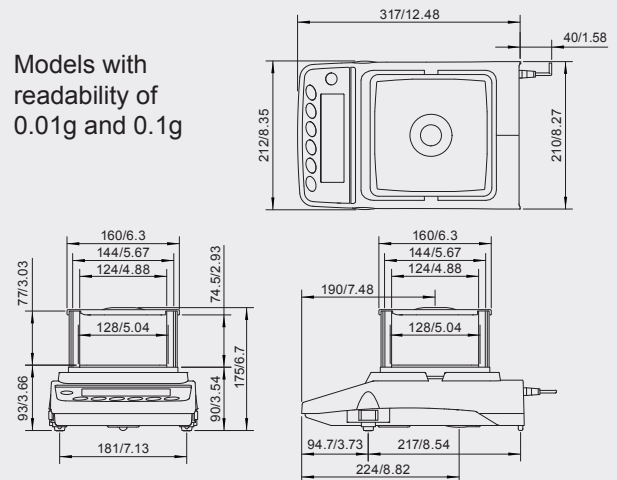

# Specifications

# Apollo GF-AWP & GX-AWP

Models	GX-A Internal calibration	GX-203AWP	GX-403AWP	GX-603AWP	GX-2002AWP	GX-4002AWP	GX-6002AWP	GX-6001AWP
	GF-A External calibration	GF-203AWP	GF-403AWP	GF-603AWP	GF-2002AWP	GF-4002AWP	GF-6002AWP	GF-6001AWP
Capacity		220 g	420 g	620 g	2200 g	4200 g	6200 g	6200 g
Readability		0.001 g			0.01 g			0.1 g
Repeatability (standard deviation)		0.001 g			0.01 g			0.1 g
Linearity		±0.002 g			±0.02 g		±0.03 g	±0.1 g
Accuracy after internal calibration (GX-A series) <sup>i</sup>		±0.010 g			± 0.10 g	± 0.15 g	± 0.15 g   5000 g	± 0.5 g   5000 g
Stabilization time		~ 1 sec (~0.8 sec for 5 g)			~ 1 sec (~0.8 sec   50 g)		~ 1 sec (~0.8 sec   50 g)	~ 1 sec (~0.8 sec for 500 g)
Sensitivity drift		±2 ppm / °C (10 °C to 30 °C / 50 °F to 86 °F, when automatic self-calibration is OFF)						
Acceptable calibration weight value		50 g 100 g 200 g	50 g 100 g (100 g interval) 400 g	50 g 100 g (100 g interval) 600 g	500 g 1000 g 2000 g	500 g 1000 g (1000 g interval) 4000 g	500 g 1000 g (1000 g interval) 6000 g	
Display		Reverse Backlit LCD (Character height: 17.8 mm)						
Display refresh rate		5 times/second, 10 times/second or 20 times/second						
Units of measure <sup>ii</sup>		g (gram), oz (ounces), lb (pound), lb-oz (pound-ounce), ozt (troy ounce), ct (metric carat), mom (momme), dwt (pennyweight), gr (grain), pcs (counting mode), % (percent mode), SG (specific gravity), and a user-programmable unit.						
Counting mode	Min unit mass	0.001 g			0.01 g			0.1 g
	Number of samples	5, 10, 25, 50 or 100 pieces						
Percent mode	Min 100% reference mass	0.100 g			1.00 g			10.0 g
	Min 100% display	0.01%, 0.1% or 1% (depends on the reference mass stored)						
Operating environment		5 °C to 40 °C / 41 °F to 104 °F, 85% R.H. or less (no condensation)						
Power supply / consumption		AC adapter / approx. 30 VA						
Communication interface		Standard: RS-232C and USB. Optional: Quick USB, LAN Ethernet (FXi-08), USB Host (GXA-24), Bluetooth Converters: AD-8529PC-W, AD8529PR-W						
Weighing pan size		128 mm × 128 mm / 5 × 5 in			165 mm × 165 mm / 6.5 × 6.5 in			
Dimensions		212 (W) × 317 (D) × 93 (H) mm / 8.3 (W) × 12.5 (D) × 3.7 (H) in						
Net weight		5 kg / 11 lb						
Weighing Applications		Counting with ACAI, % Weighing, Animal Weighing, Density Determination, Statistical Calculation, Comparator HI OK LO, Underhook, Gross/Net/Tare						
Options		Interfaces: GXA-03 2nd RS232, GXA-04 Comparator Relay, GXA-06 Analog output   External Key Input Interfaces: GXA-23-PRINT, GXA-23-REZERO, GXA-23-PLUG   Breeze Break: GXA-10 Large BB, GXA-17 Large BB with Ionizer   GXA-13 Density Kit, GXA-25 External Ionizer, GXA-26 External IR Switch, GXA-12 Animal Weigh Pan						
Accessories		TB247 Power Supply, AD-8127 Compact Printer, AD-1682 External Rechargeable Battery (for more accessories visit <a href="http://andweighing.com">andweighing.com</a> )						

<sup>i</sup> Under stable environment (no rapid temperature/humidity change, vibration, draft, magnetism, static, etc). The mass of the internal weight may vary with age.

<sup>ii</sup> One additional unit from tael (Singapore/HK jewelry/Taiwan/China), tola or Newton can be added upon request.

## Key Features:



4622 Runway Blvd  
Ann Arbor, MI 48108  
888-726-5931 or 408-263-5333  
[andweighing.com](http://andweighing.com)

