



Built for Sophisticated, Professional Weighing.

When laboratory work and research requires accuracy to the hundred-thousandth, there is simply no room for error. The Explorer series of semi-micro balances has been designed with the technology to ensure that your very specific weighing results are accurate. Sophisticated laboratories requiring accuracy and looking for innovative technology to obtain measurement results can find both in Explorer semi-micro balances.

Standard Features Include:

- **Intelligent Performance for Applications Requiring Extreme Accuracy**—The semi-micro Explorer series, which includes models with capacities up to 220 g and resolutions up to 0.01 mg, has been designed to use a High Speed Single Module weighing cell to ensure the accuracy of results. To minimize weighing errors and ensure accurate measurements, AutoCal™ utilizes two internal weights to perform a linear calibration.
- **Intuitive Software Provides an Extremely Modern User Experience**—Powered by SmarText™ 2.0 software, Explorer operates in the same manner as common electronics, with an icon-based touchscreen display, advanced applications, memory library, a USB host port, and more.
- **Ingenious Construction Designed to Enhance Usability**—Among Explorer's features designed to improve user experience and ensure the integrity of results include touchless sensors, automatic draftshield doors, an ionizer, and more.

Explorer[®] Semi-Micro Balances

Intelligent Performance for Applications Requiring Extreme Accuracy

Balances with capacities ranging from 52 g–220 g and readabilities from 0.1 mg–0.01 mg make up the Explorer series of semi-micro balances. In addition to superior craftsmanship and a High Speed Single Module weighing cell, various features are incorporated in to the product's design to enhance performance.

Internal Calibration

OHAUS' signature AutoCal™ internal calibration system provides routine maintenance by automatically calibrating the balance every time it senses a temperature change of 1.5°C or every 3 hours, whichever occurs first. This helps ensure the accuracy of the balance when the operator has not performed a manual calibration or when the proper calibration masses are unavailable. In addition, to minimize weighing errors and ensure accurate measurements, AutoCal™ utilizes two internal weights to perform a linear calibration.

Efficiency

Explorer's ultra-fast stabilization time (0.1 mg: ≤3 second, 0.01 mg: ≤8 second) and audible stability alert increases laboratory efficiency.

Intuitive Software Provides an Extremely Modern User Experience

Explorer semi-micro balances include many facets of modern technology to provide the best weighing experience possible. The icon-based navigation provides tactile feedback and operates in the same manner as a smart phone or tablet computer.

Save to USB

A USB host port provides the capability of using a USB extension cable to directly transfer the data to a flash drive.

Memory

The balance's memory capabilities includes a library with space for up to 99 items, and a 10 recipe library for formulation mode.

Multi-User

The user manager function provides profiles for one administrator and five additional users, allowing multiple users to utilize the same balance without compromising past results recorded on the balance.

Technology

- Other technologically-advanced features include:
- Below minimum sample weight indicator
- Real time clock for GLP/GMP data collection
- Audible stability alert
- True type printing for SQC and pipette adjustment.



Ingenious Construction Designed to Enhance Usability

The sleek Explorer semi-micro balance has been designed and constructed to provide a modern weighing experience as well as to bolster accuracy.

Operator Experience

Among the features that enhance the operator experience are:

- Color touchscreen display
- Four programmable touchless sensors allow the operator to perform common functions and commands with a swipe of the hand
- Modular design in which the base and display can be separated to allow the balance to fit ideally on the lab bench.

Auto-Doors

The automatic door on certain models allows the user to open the draftshield door with a wave of their left hand when their right hand is occupied with the sample. This feature allows the sample placement process to occur in one swift motion without having to repetitively pick up and put down samples due to a lack of free hands. The automatic doors are more than just a user-friendly feature, they minimize vibrations caused by manual operation which can affect weighing results.

Ionizer

The built-in ionizer, included in Explorer automatic door models, generates bipolar ions continuously from positive and negative discharge electrodes and directs the ionized air onto the charged body to eliminate static electricity. These charges can build up in the weighing chamber and alter weighing results by as much as several milligrams.



Outline Dimensions

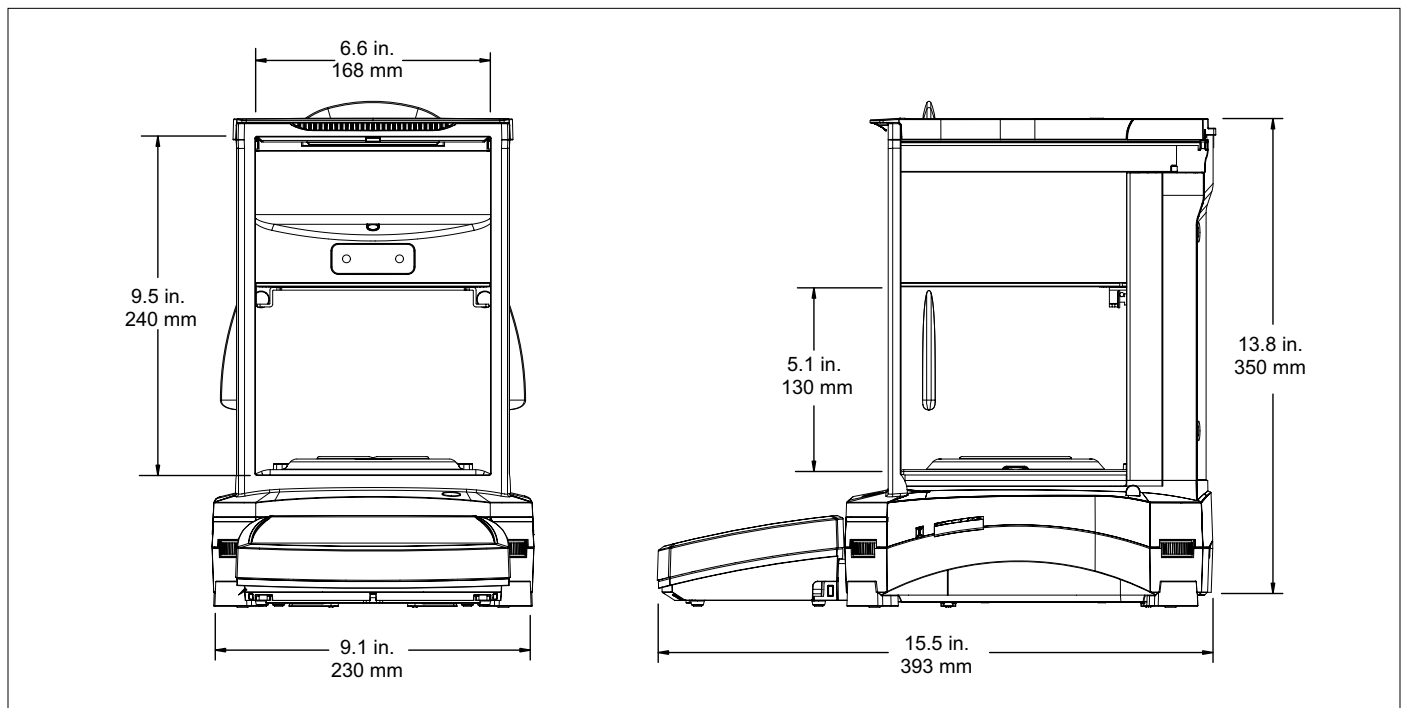

Explorer[®] Semi-Micro Balances

MODEL	EX125D	EX125	EX225D	EX225D/AD	EX225/AD
Capacity	52 g / 120 g	120 g	120 g / 220 g	120 g / 220 g	220 g
Readability (d)	0.01 mg / 0.1 mg	0.01 mg	0.01 mg / 0.1 mg	0.01 mg / 0.1 mg	0.01 mg
Repeatability (@20g)	0.015 mg				
Repeatability (@ Capacity)	0.1 mg	0.02 mg	0.1 mg	0.03 mg	0.03 mg
Linearity	±0.1 mg				
Span Calibration Points	50 g 100g	50 g 100g	100 g 150g 200g	100 g 150g 200g	100 g 150g 200g
Calibration	Standard AutoCal™, AutoCal on Δ1.5° temperature change, 3 hours				
Automatic Door	n/a			Standard*	
Weighing Units	g, mg, kg, ct, gn, oz, ozt, lb, dwt, N, mom, tical, msg, tola, baht, Hong Kong Tael, Singapore Tael, Taiwan Tael, Custom Units 1, Custom Unit 2, Custom Unit 3				
Applications	Weighing, Parts Counting, Percent Weighing, Checkweighing, Dynamic Weighing, Filling, Totalization, Formulation, Differential Weighing, Peak Hold, Density Determination, Pipette Adjustment, Statistical Quality Control				
Stabilization Time	0.1 mg: ≤3 second, 0.01 mg: ≤8 second				
Sensitivity Temp. Drift	0.50 ppm / °C				
Display	5.7 in / 14.5 cm (diagonal) Full-Color touch screen				
Interface	Standard connectivity: 1 USB host, 1 USB device, 1 RS232 Optional connectivity: 2 nd RS232, Ethernet				
Working Environment	10°C – 30°C / 50°F – 86°F, 85% RH, non-condensing				
Storage Conditions	-14°F (10°C) to 140°F (60°C) at 10% to 90% relative humidity, non-condensing				
Power Supply	AC Adapter Input: 100 – 240 VAC 0.6 A 50/60 Hz, AC Adapter Output: 12 VDC 1.5 A				
Pan Size (diameter)	3.1 in / 80 mm				
Dimensions (W × H × D)	9 × 15.5 × 13.8 in / 230 × 393 × 350 mm				
Shipping Dimensions (W × H × D)	24.9 × 25.2 × 18.4 in / 632 × 640 × 467 mm				
Net Weight	15.4 lb / 7 kg			16.5 lb / 7.5 kg	
Shipping Weight	26.5 lb / 12 kg			27.8 lb / 12.6 kg	

*Two motorized doors operated by 4 sensors or onscreen button
For specifications related to the United States Pharmacopoeia (USP) minimum weight standard visit www.Ohaus.com/USPMinWeight

Approvals

- **Product Safety:** CAN/CSA C22.2 61010-1, UL 61010-1, IEC 61010-1
- **Electromagnetic Compatibility:** FCC Part 15 (Class A), Industry Canada ICES-001 (Class A), IEC 61326-1, (Class B emissions, Industrial immunity)

Accessories

Ethernet Interface83021082
Terminal Extension Cable83021083
Interface Cable USB83021085
Density Determination Kit80253384
Security Device Kit80850043
Dot Matrix Printer	SF-40A
Cable kit to connect Dot Matrix Printer80252571
Paper for Dot Matrix Printer80251932
Ink Ribbon for Dot Matrix Printer80251933
RS232 Cable, PC 9 Pin80500525
USB Extension Cable30215156
ION-100A Ionizer30130302
Dust Cover30093334

80774834_B 20170907 © Copyright OHAUS Corporation

OHAUS CORPORATION
* 7 Campus Drive
Suite 310
Parsippany, NJ 07054 USA
Tel: 800.672.7722
973.377.9000
Fax: 973.944.7177
www.ohaus.com
With offices throughout
Europe, Asia, and
Latin America
*ISO 9001:2008
Registered Quality
Management System

